

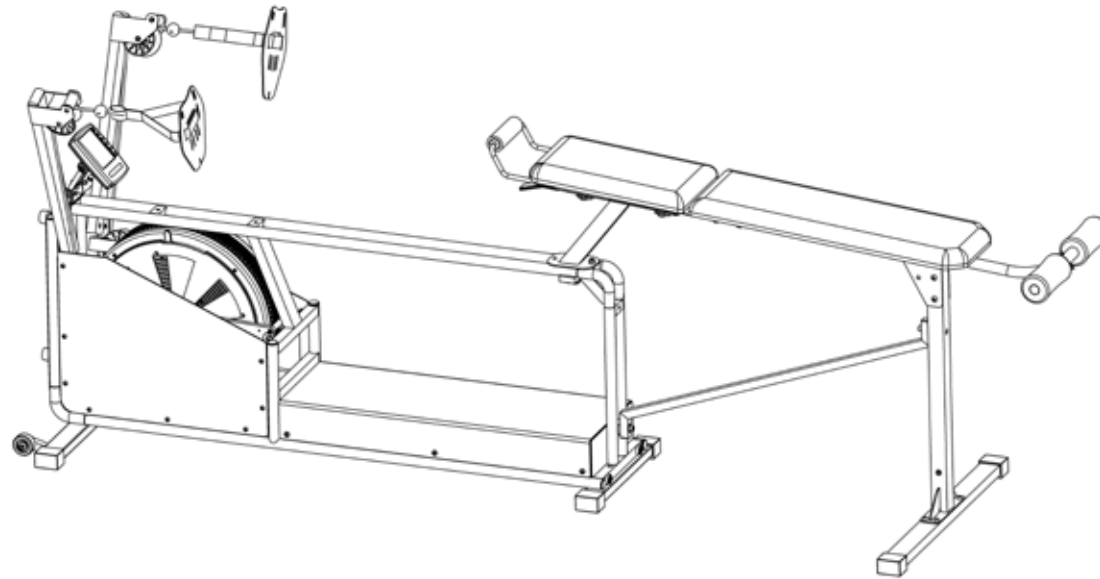

ASSEMBLY INSTRUCTIONS



KAYAKPRO[®]

1

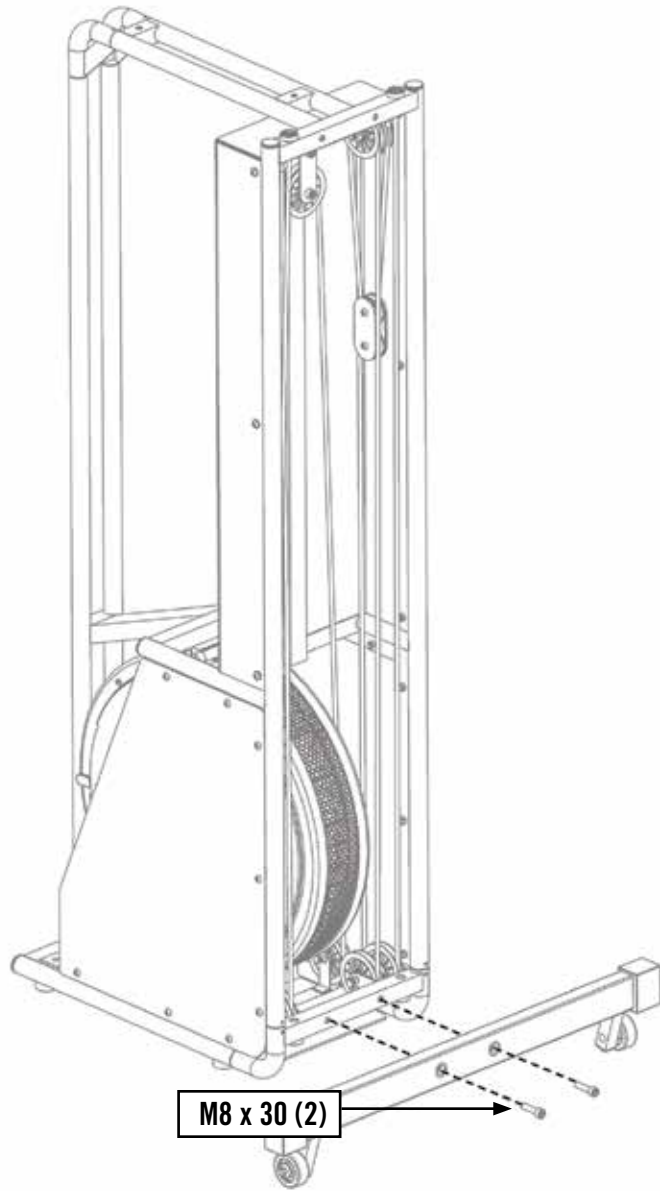

2

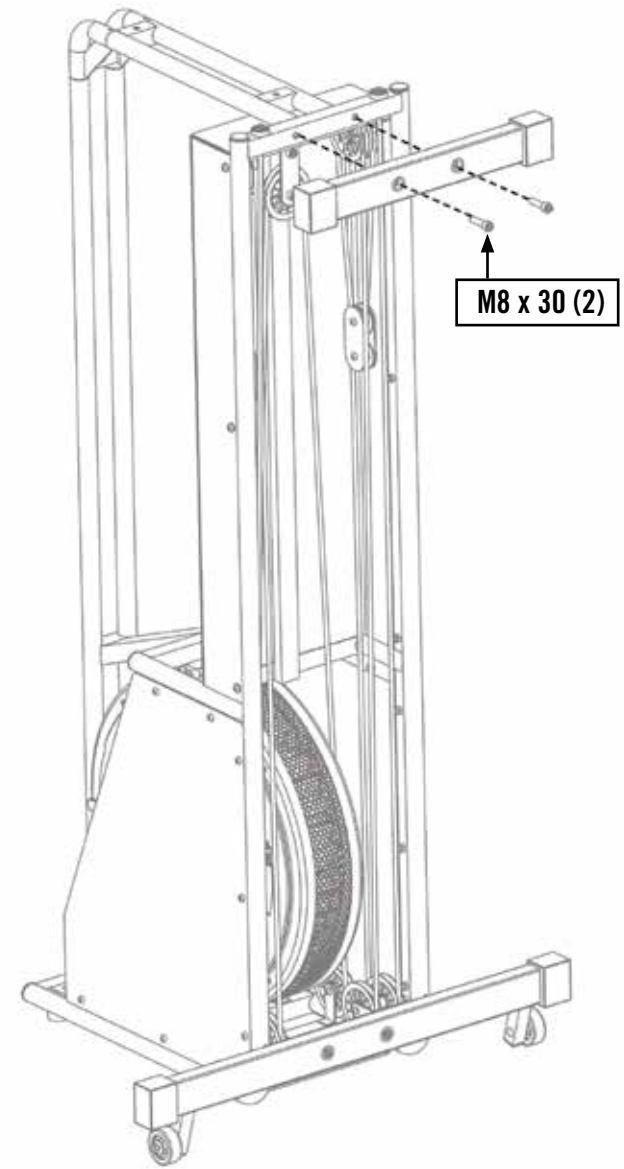

3

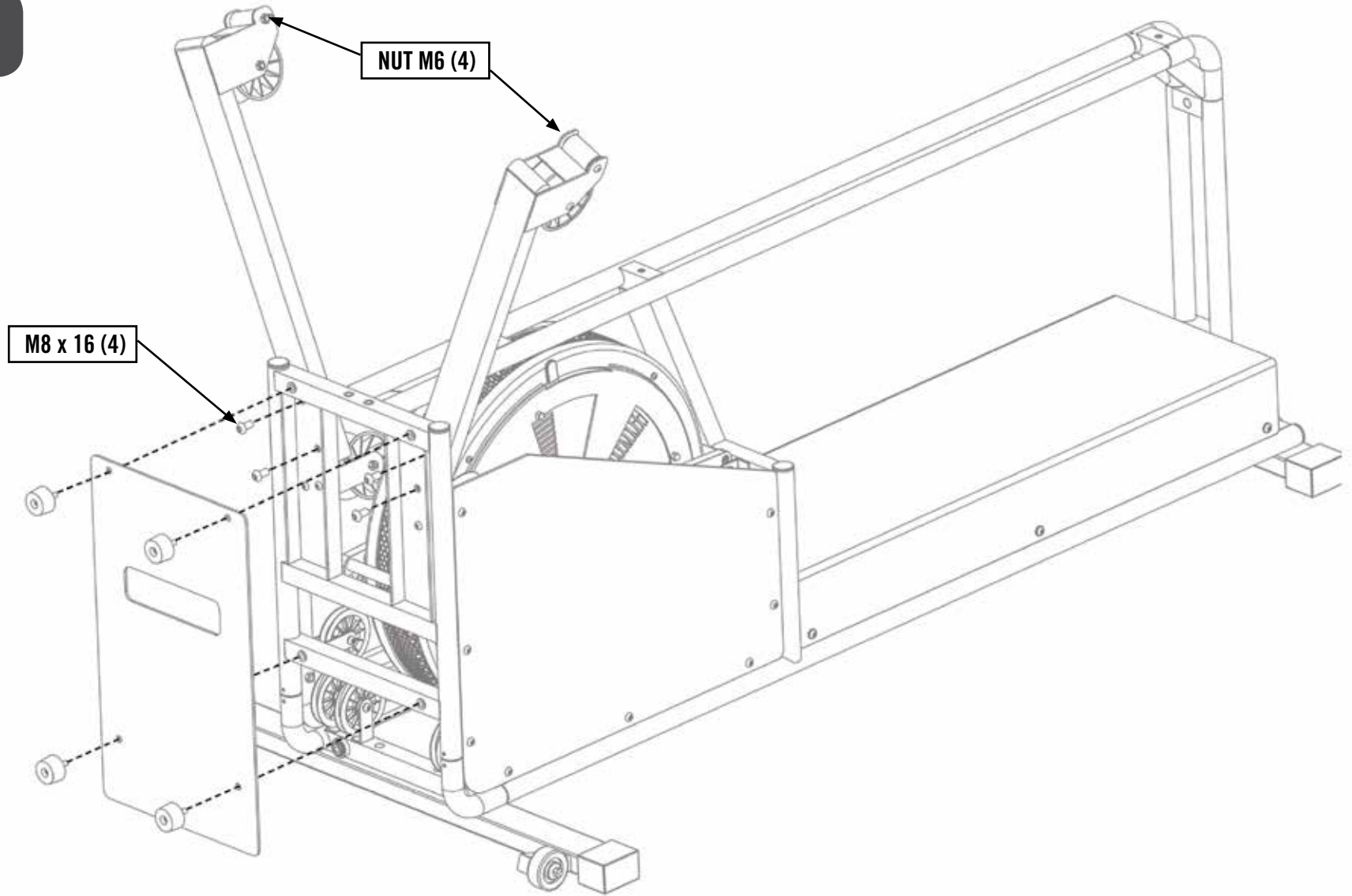

4

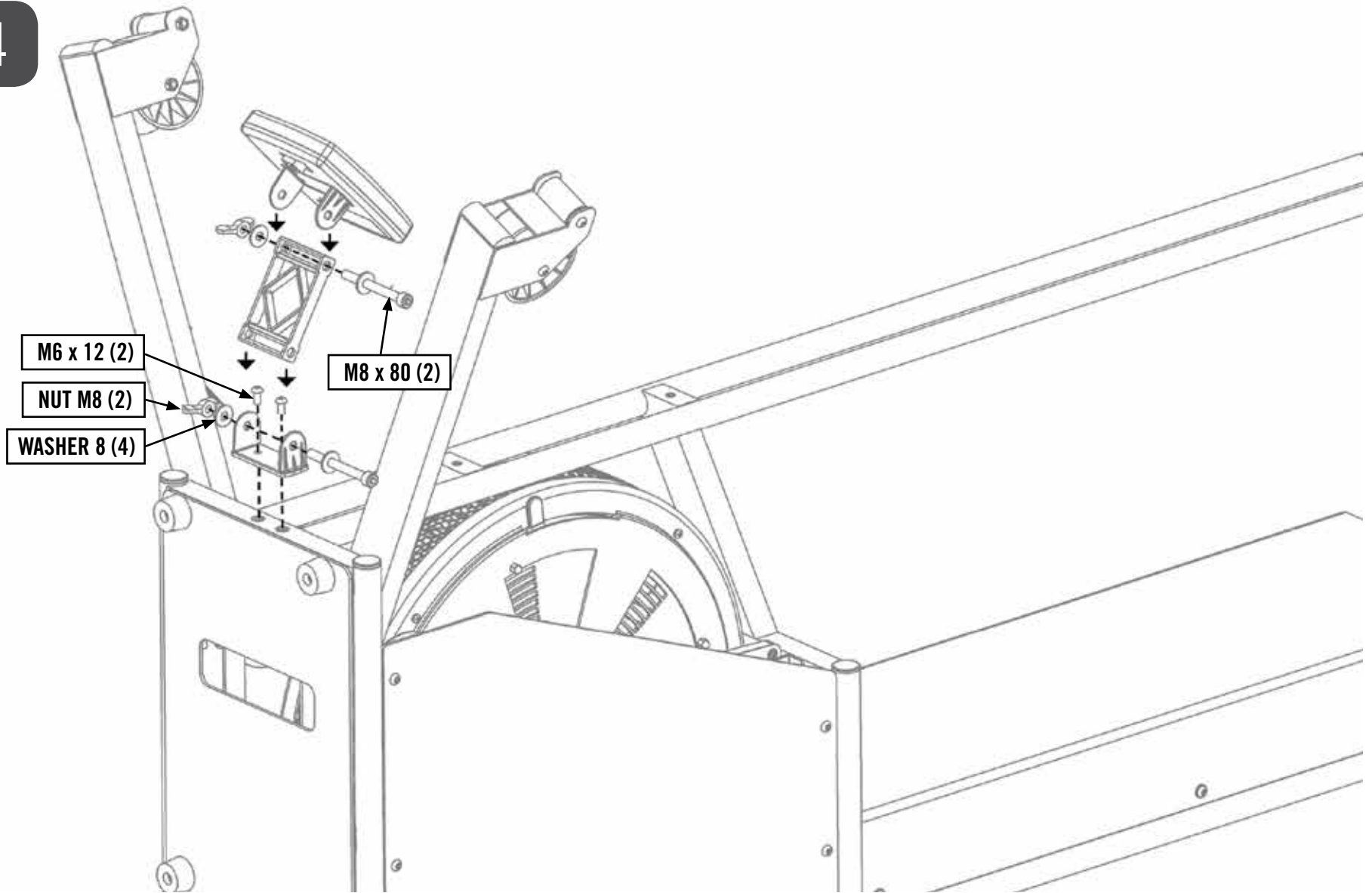

5

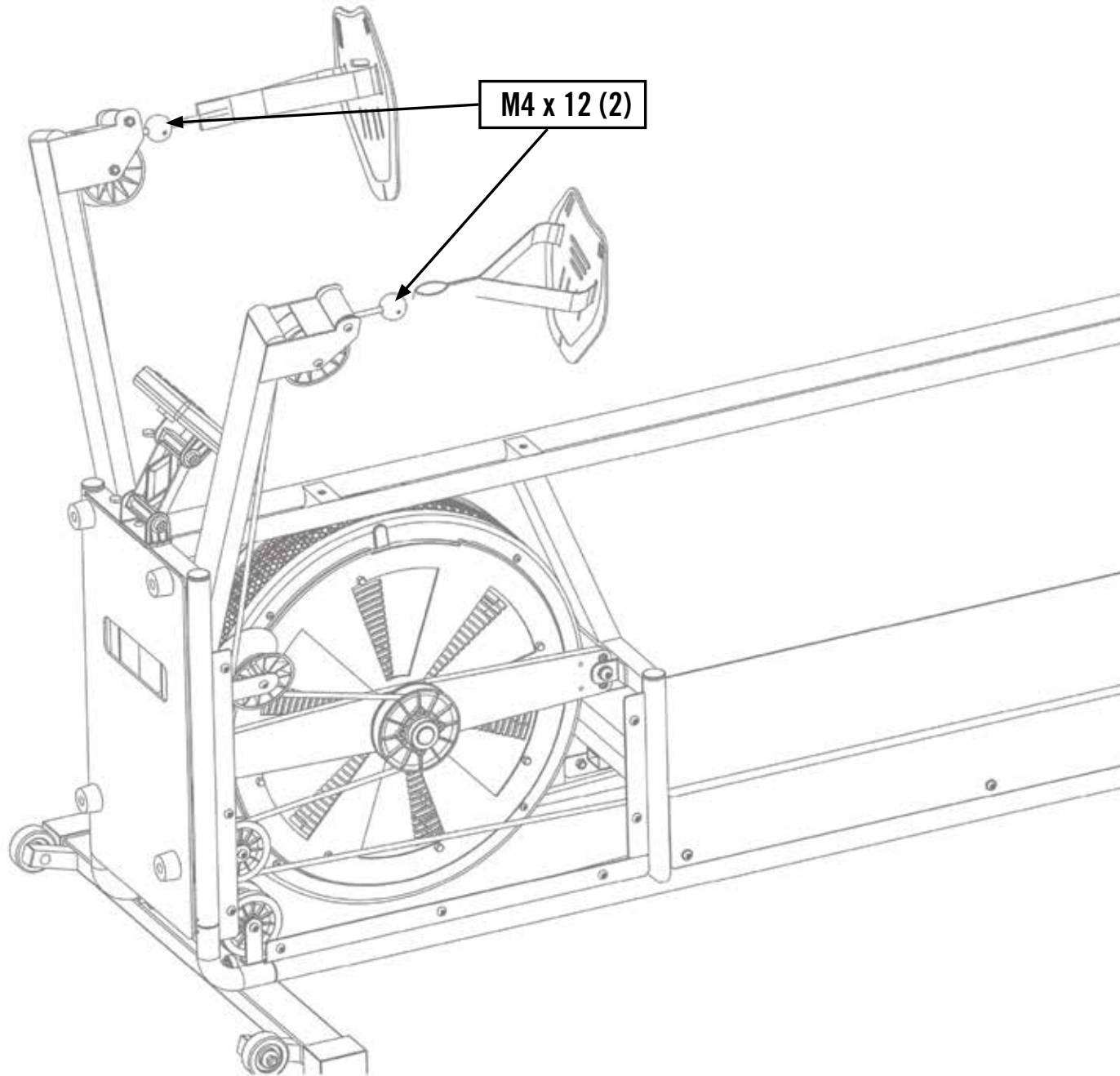

6

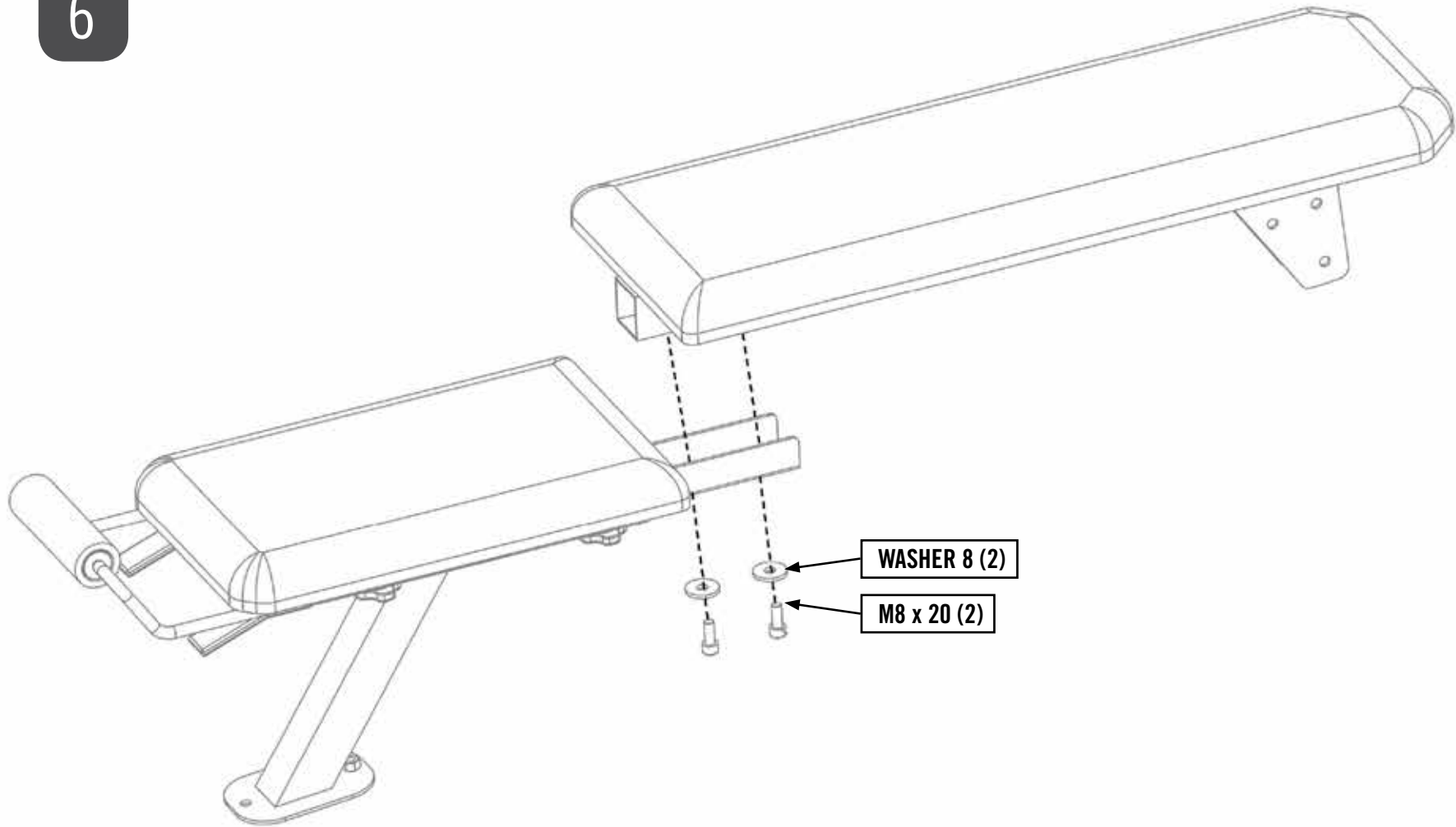

7

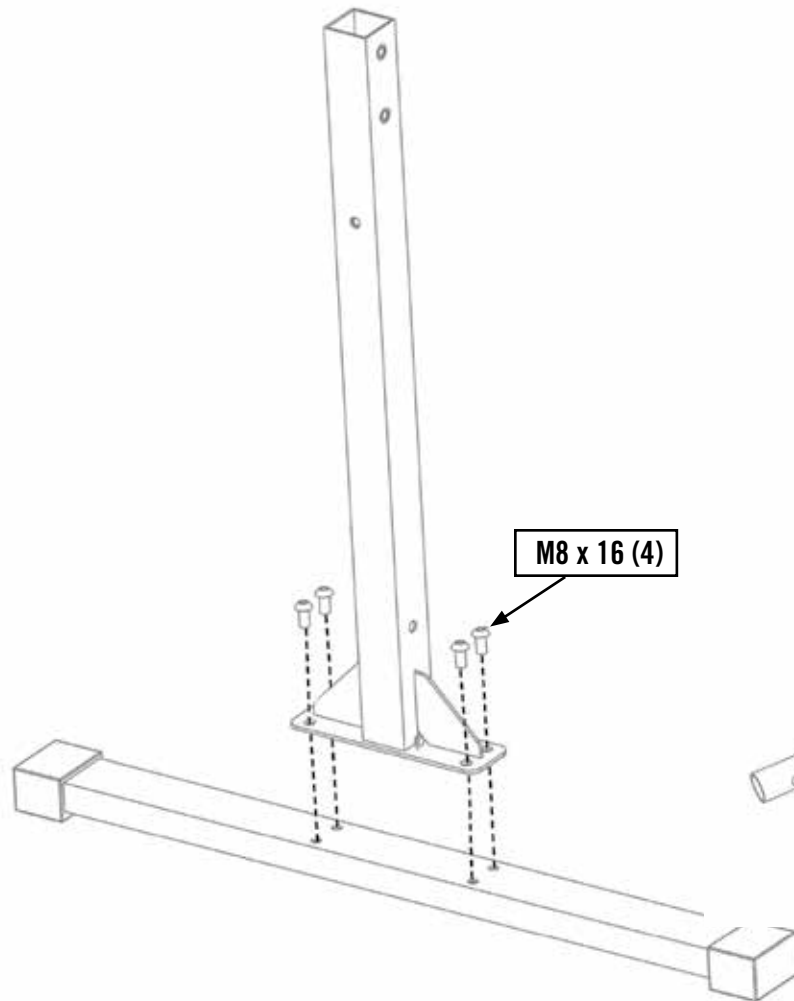

8

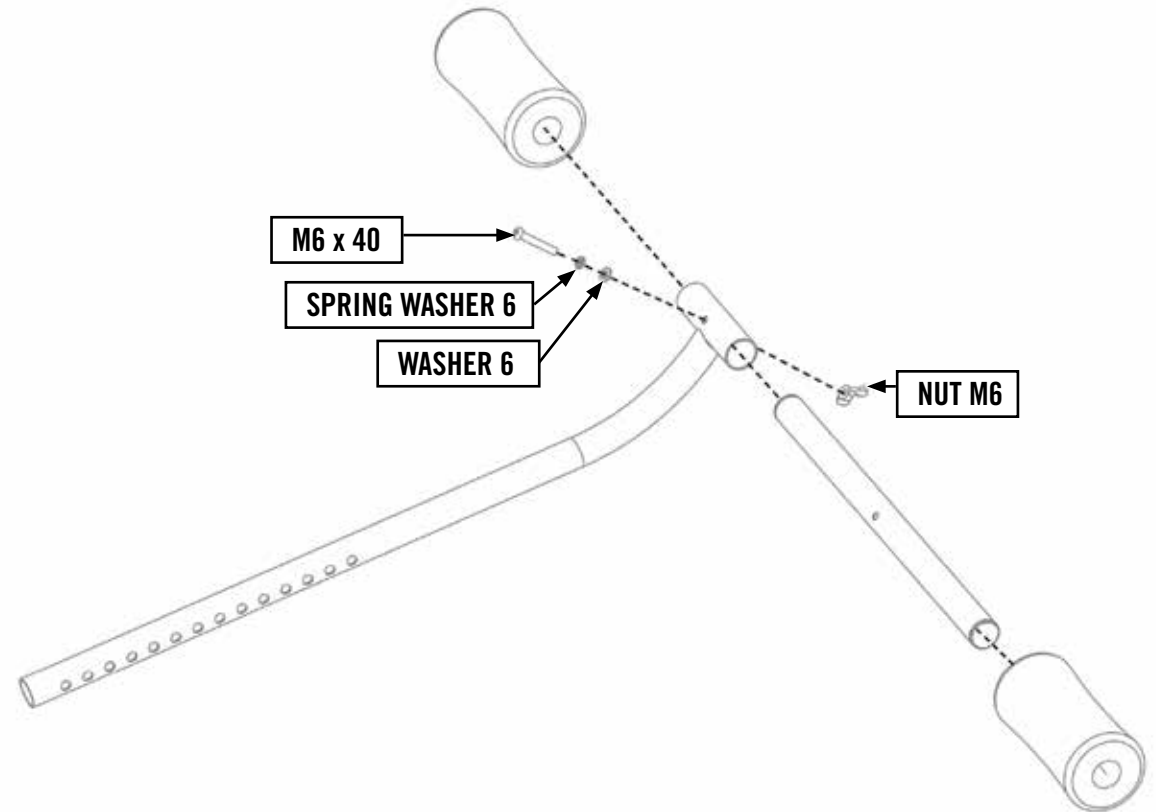

9

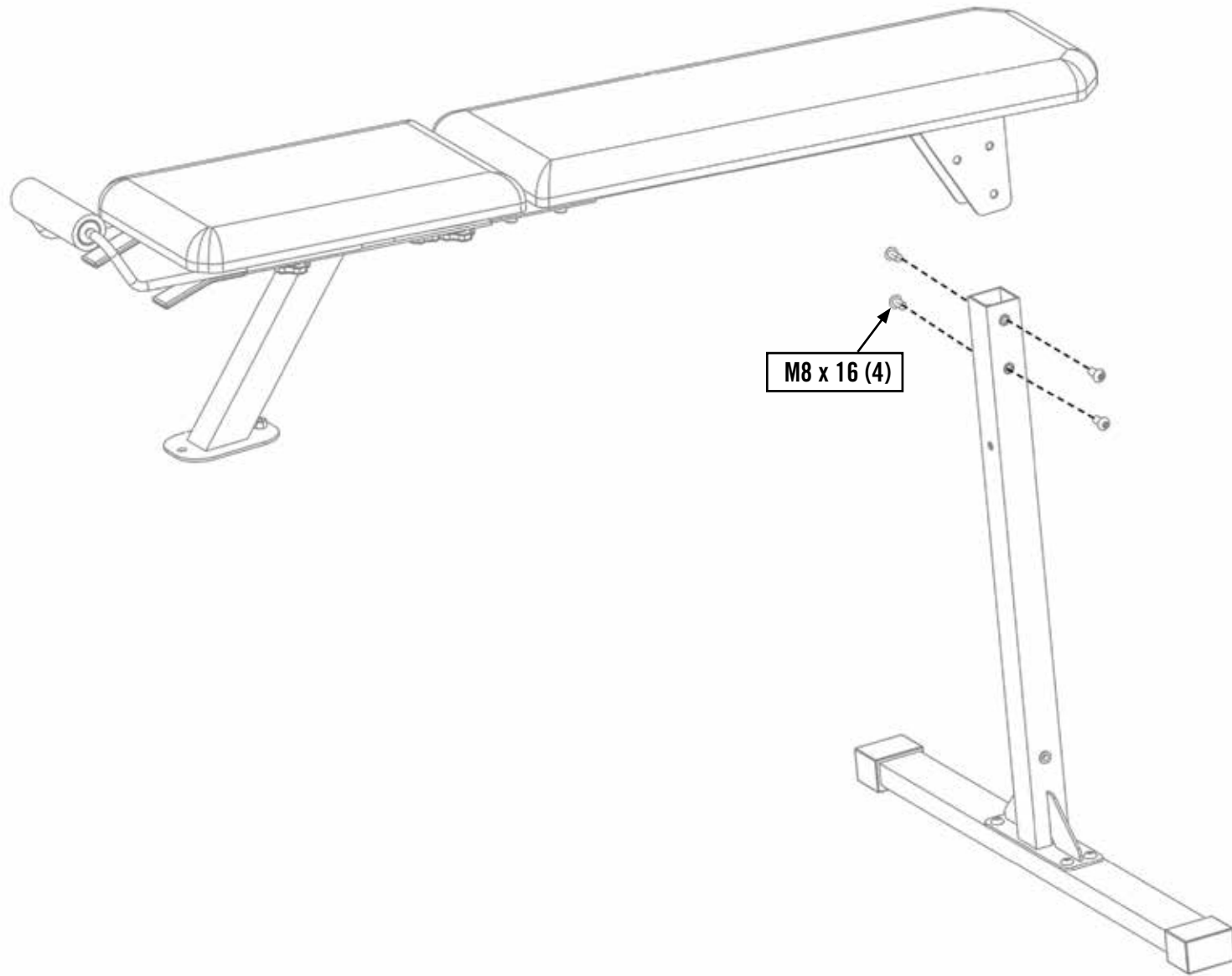

10

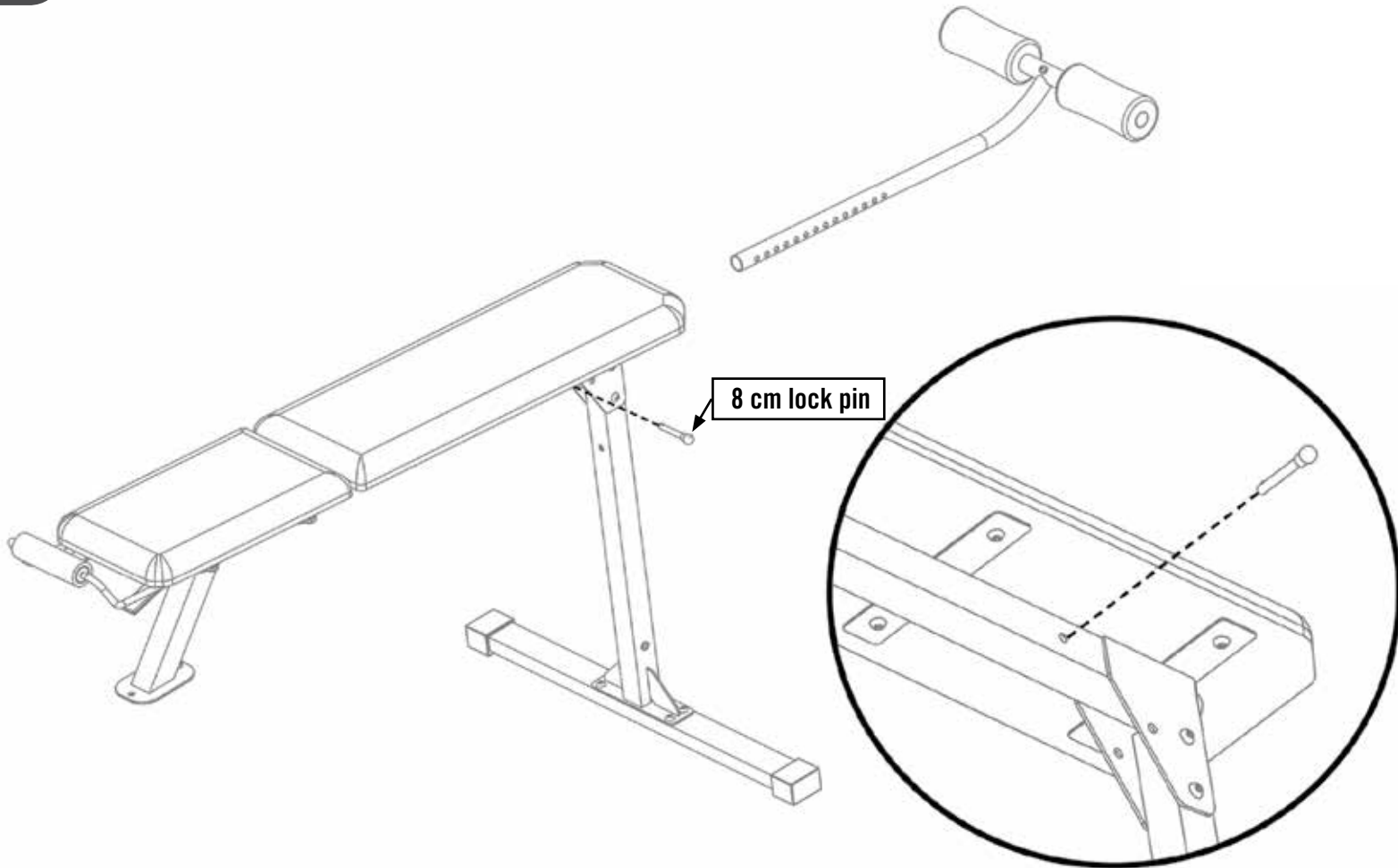

11

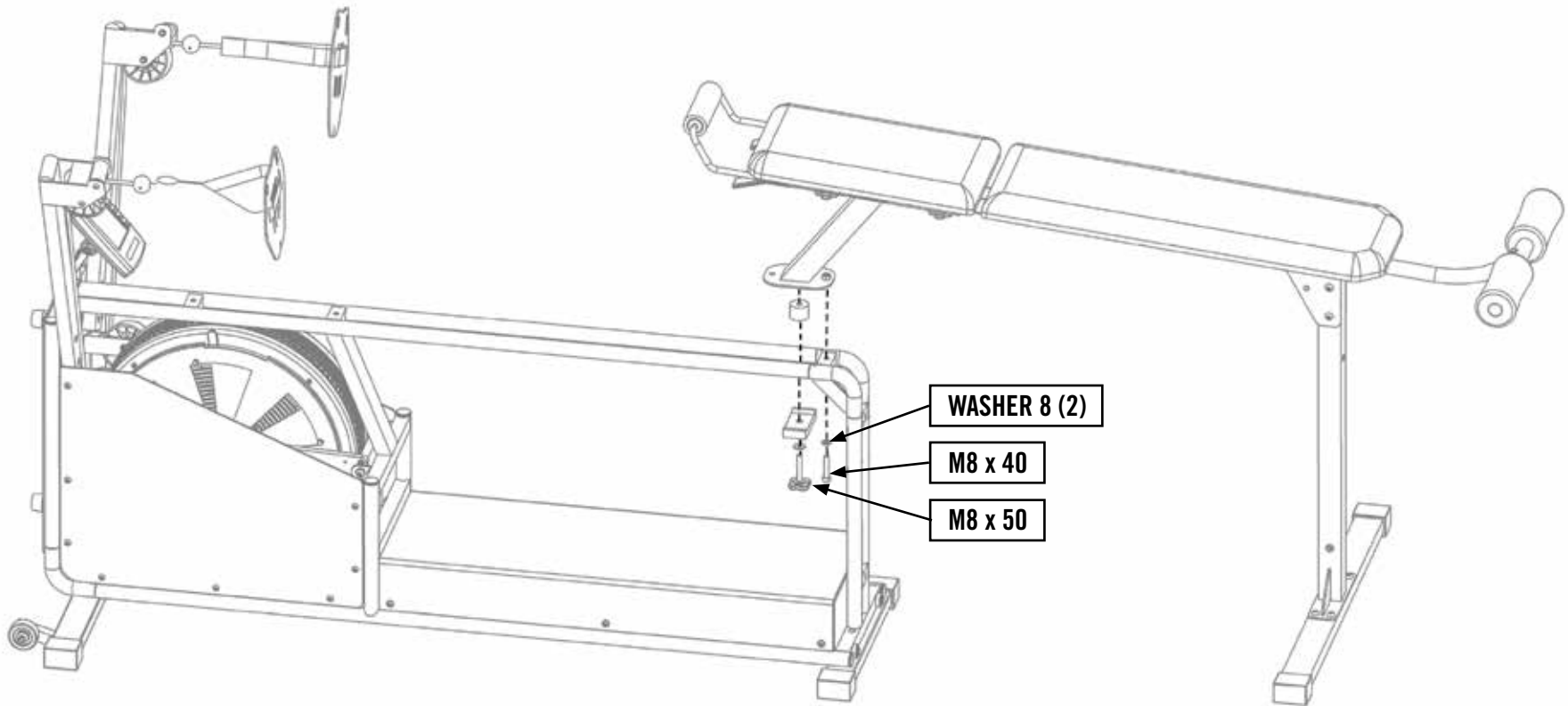

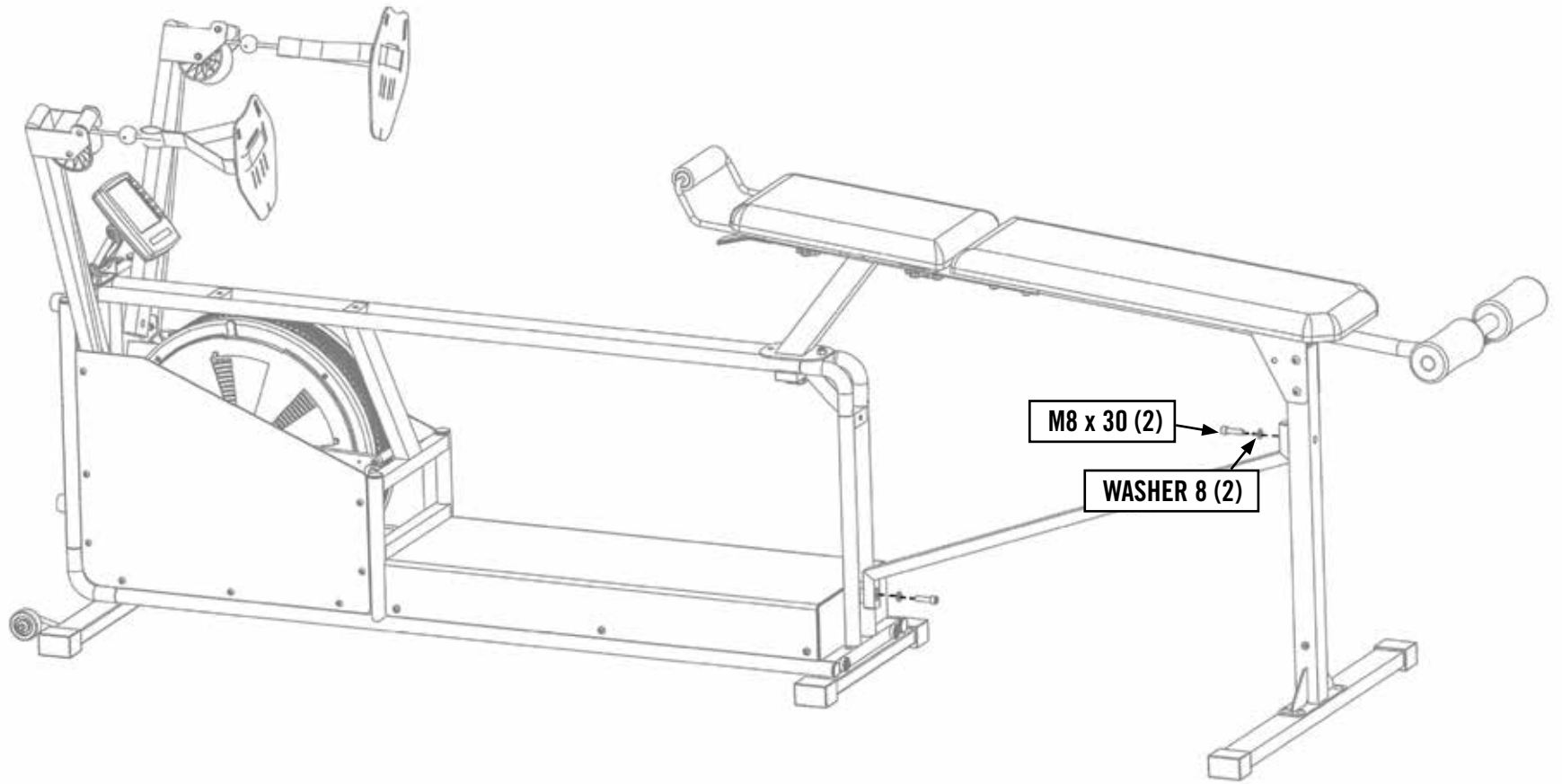

SAFETY PRECAUTIONS

SAFE OPERATION AND USE

SERIOUS INJURY CAN OCCUR IF THE FOLLOWING PRECAUTIONS ARE NOT OBSERVED.

1. Always consult your physician prior to undertaking any exercise regimen.
2. Keep head, limbs, fingers, and hair clear of all moving parts and flywheel cage.
PLEASE NOTE For the SwimFast Ergometer, working area is:
TOTAL WIDTH 3.2 m (126")
TOTAL LENGTH 1.6 m (63")
3. Inspect machine prior to use. Do not use the machine if it appears damaged or inoperable.
4. Contact manufacturer if machine is broken or jammed.
5. Use machine only as intended.
6. Do not modify the machine.
7. Children must not be allowed near this machine.
8. Teenagers must be supervised in the use of this machine.
9. By using the SwimFast Ergometer the user accepts all and full responsibility for self.



CONTACT US

PaddlePro NZ
www.paddlepro.co.nz

info@paddlepro.co.nz



ATHENS 2004



Beijing 2008



London 2012



KAYAKPRO USA LLC OFFICIAL SUPPLIERS OF
KAYAK AND CANOE ERGOMETERS TO THE
2004, 2008 AND 2012 OLYMPIC GAMES